

Tender Notice No : CPMPT - 15/ 24-25.

Annexure 3

**TECHNICAL SPECIFICATION FOR THE 11 KV HG FUSE SETS
WITH POLYMER INSULATORS**

- 1.0 **SCOPE:** The Specification provides for manufacturers testing before dispatch, supply and delivery of 11KV H.G Fuse sets with polymer insulators for use of distribution side as per the particulars given in the schedule attached.
- 2.0 **APPLICABLE STANDARDS:** The 11KV H.G Fuse Sets shall conform in all respects to the clause (4) Technical Particulars given below. The Insulators conform to the following standards with latest Version applicable as on date. **The insulators shall be invariably procured from registered vendors of CPDCL only.**

Sl. No.	Indian Standard	Title	International Standard
1.		Definition, test methods and acceptance criteria for composite insulators for a.c. overhead lines above 1000V	IEC : 61109
2.	IS : 2071	Methods of High Voltage Testing	IEC : 60060-1
3.	IS : 2486	Specification for insulator fittings for overhead power lines with a nominal voltage greater than 1000V General Requirements and Tests Dimensional Requirements Locking Devices	IEC : 60120 IEC : 60372
4.		Thermal Mechanical Performance test and mechanical performance test on string insulator units	IEC : 60575
5.	IS : 13134	Guide for the selection of insulators in respect of polluted conditions	IEC : 60815
6.		Characteristics of string insulator units of the long rod type	IEC : 60433
7.		Hydrophobicity classification guide	STRI guide 1.92/1
8.		Radio interference characteristics of overhead power lines and high-voltage equipment	CISPR:18-2 part 2
9.	IS : 8263	Methods of RI Test of HV Insulators	IEC : 60437
10.		Standard for insulators – Composite-Distribution Dead-end type	ANSI C29 13-2000
11.	IS : 4759	Hot dip zinc coatings on structural steel & other allied products	ISO : 1459 ISO : 1461
12.	IS : 2629	Recommended Practice for Hot, Dip Galvanization for iron and steel	ISO-1461 (E)
13.	IS : 6745	Determination of weight of zinc coating on zinc coated iron and steel articles	ISO : 1460
14.	IS : 3203	Methods of testing of local thickness of electroplated coatings	ISO : 2178
15.	IS : 2633	Testing of Uniformity of coating of zinc coated articles	
16.		Standard specification for glass fiber strands	ASTMD 578-05
17.		Standard test method for compositional analysis by Thermogravimetry	ASTM E 1131-03
18.	IS : 4699	Specification for refined secondary zinc	

- 3.0 **CLIMATE CONDITIONS:** The climatic conditions under which the equipment shall operate satisfactorily are as indicated in Clause 23.1 of General and Financial terms and conditions for supply of materials.

- 4.0 **CONSTRUCTION:**

- 4.1. All ferrous parts shall be hot dip galvanized as per IS-2633. The Fuse Sets are meant for mounting on a structure at a height of 4.5 meters to 5.0 meters from ground level suitable for Single Pole Distribution Transformers structure.
- 4.2. The Polymer parts shall be permanently secured at the centre in a metal support to be mounted on the supporting structure. They shall be made up of inter changeable units and shall be capable of being mounted on the supporting structures. Suitable Bolts, Washers required shall also be supplied with the insulators. The portion of the central metallic support where it grips the insulator should be insulated to that level of the insulators to avoid bird faults.

The Polymer shall be sound and homogenous, free from defects and other flaws of imperfections which might affect the mechanical or dielectric strengths. They should be thoroughly vitrified and shall be tough, impervious to moisture and smoothly glazed.

All the ferrous metal parts excluding mounting angles shall be hot dip galvanized. The mounting angles shall be painted with double coat of red oxide paint. The Polymer and metal parts shall be assembled in such a manner that any thermal expansion differential between the metal and Polymer parts throughout the range of temperature variation shall not loosen the parts or create undue internal stresses which may effect the electrical or mechanical strength and rigidity.

- 4.3 All the bolts and nuts shall be hot dip galvanized.

5.1 TECHNICAL PARTICULARS:

- | | | | |
|-------|---|---|--------------------------------|
| 5.1.1 | Rated Current | : | 50 A |
| 5.1.2 | Rated Voltage | : | 12 KV |
| 5.1.3 | Rated Insulation Level | | |
| a). | Power Frequency Withstanding Voltage | | |
| i). | To Earth and Between Poles | : | 28 KV (RMS) |
| ii). | Across Isolating Distance | : | 32 KV (RMS) |
| b). | Impulse Withstand Voltage | | |
| i). | To Earth and Between Poles | : | 75 KV (Peak) |
| ii). | Across Isolating Distance | : | 85 KV (Peak) |
| 5.1.4 | Temperature Rise | : | 50 Degree C above ambient temp |
| 5.1.5 | Resistance Across the Terminals
(Excluding Fuse Wire Resistance) | : | 1 m.Ohm |

- 5.1.6 The Gap for the Fuse Wire Shall be : 203 mm
- 5.1.7 Phase to Phase Clearance of the Fuse Sets shall be : 600 mm
- 5.1.8 Insulator Support Height Including Insulator Diameter Shall be (30 x 5mm M.S Flat) : 254 mm
- 5.1.9 Arcing Horn Straight Portion shall be : 75 mm
- 5.1.10 Arcing Horn Bending Portion shall be (i.e. From 60 Degree Angle) : 383 mm

5.2. INSULATORS

1.	Make	Any standard approved make	
2.	Type	Polymer insulators	
3.	Nominal System Voltage	11KV	
4.	Highest System Voltage	12KV	
5.	System Frequency	50Hz	
6.	Dry Power frequency withstand voltage /wet	70KV(rms)	
7.	wet Power frequency withstand voltage	50KV(rms)	
8.	Dry Lighting Impulse withstand voltage	120KVp	
9.	Visual discharge voltage	9KV(rms)	
10.	RIVat1MHzwhen energized10 KV (RMS) under Dry condition	<100microV	
11.	Creepage distance	700mm(min)	
	Dry Arcing Distance	390mm(min)	
12.	No of Sheds	6	
13.	Weight(Approx)	1KG	
14.	Applicable Standards	Insulator- IEC-61109-2008 Galvanisation- IS2633-1986	
15.	Total length of the insulator shall be	350mm+/-5	
16.	Diameter of the insulator shall be	85mm+/-5	
17.	Tolerance	1)+/- (0.04xd+1.5)mm when d<=300 mm 2)+/- (0.025xd+6)mm when d>300 mm	
18.	Product details	Polymer housing, Core Rod with top-fitting, bottom- fitting	

6.0 TESTS

6.1. Type Tests

- i). Lightning Impulse Withstand Test.
- ii). Power Frequency Voltage Withstand Test (Dry).
- iii). Power Frequency Voltage Withstand Test (Wet).
- iv). Temperature Rise Test.
- v). Measurement of Resistance.

6.2. Acceptance

- i). Verification of Dimensions.
- ii). Galvanising Test.
- iii). Temperature Rise Test.
- iv). Measurement of Resistance.
- v). Dielectric Test (with 1000V Megger)
- vi). Power Frequency Voltage Withstand Test (Dry).

6.3. Routine Tests

- i). Verification of Dimensions.
- ii). Temperature Rise Test.
- iii). Measurement of Resistance.
- iv). Dielectric Test (with 1000V Megger)
- v). Power Frequency Voltage Withstand Test (Dry).

Note: 1. A copy of Type Test Certificates for 11KV H.G Fuse Sets and Insulators shall be furnished along with tender without which the tender is liable for rejection.

2. Type Test Certificates from NABL Laboratories tested not earlier than **5 years** shall be enclosed. If any change in design as made latest type tests shall be furnished along with approved drawing. The Bids received without type test reports will be liable for rejection

7. **TESTS AND TEST CERTIFICATES:** The tests shall be carried out as per clause (6) above and relevant ISS for both H.G Fuse Sets and the Insulators before dispatch and the test certificates shall be furnished for approval.

8. **INSPECTION:** All the routine and acceptance tests and inspection shall be made at the place of manufacturer unless otherwise especially agreed to by the manufacturer and purchaser at the time of purchase. The manufacturer shall offer the inspector representing the purchaser all reasonable facilities, without charge to satisfy him that materials are being furnished in accordance with this specification.

The purchaser has the right to have the tests carried out at supplier cost by an independent agency whenever there is dispute regarding the quality of supply.

9. **PACKING:** The 11 KV H.G Fuse Sets shall be delivered suitably packed. Although the method of packing is left to the discretion of the manufacturer, it should be robust for rough handling that is occasioned during transportation by Rail/ Road.

Each 11 KV H.G Fuse Sets (Protection Kits) system set may be marked as follows:

- a). Name of the Manufacturer.
- b). Name of the Product.
- c). CPDCL Purchase Order No. & Date.
- d). Manufacture Month & Year.
- e) **CPDCL name shall be punched with the size of 10 mm on main angle of 11 KV HG Fuse Set**

10. **GUARANTEE TECHNICAL PARTICULARS:** The Technical Particulars as specified at clause (5) above shall be guaranteed and a statement of Guarantee Technical Particulars shall be furnished along with the tender.

11. **DRAWINGS:** Three sets of detailed dimensional drawings of each part of the complete 11KV H.G Fuse Sets along with operating instructions shall be submitted along with the tender.

12. **GENERAL:**

- i). Only standard Polymer insulators are to be used in the manufacture of H.G Fuse Set. This shall be clearly confirmed in the tender.
- ii). Any design other than one specified herein may also be offered. However, the APCPDCL reserves the right to make purchase according to the specification.
- iii). The tenderer shall submit relevant Type Test Certificates of NABL along with the tender. If the Type Test Report is not enclosed with the tender, such tenders are liable for rejection.

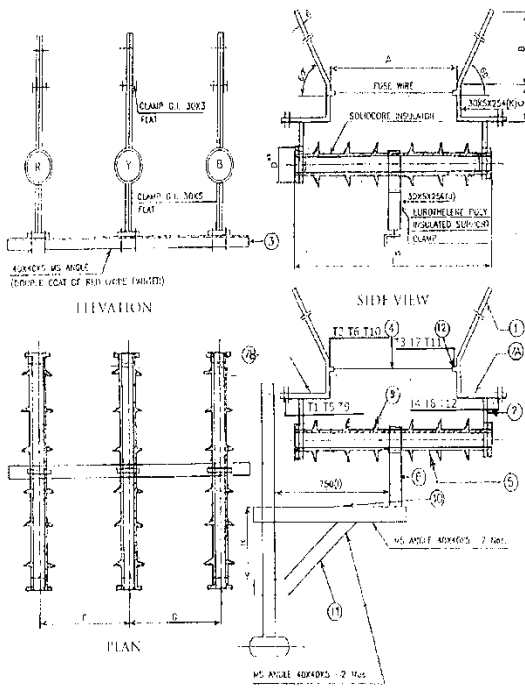

BILL OF MATERIAL

Sl No	Item Description	Quantity
1.	Horn Rod 8mm	6 Nos
2.	Horn Support Fixing Clamp 30X3mm	12 Nos
3.	HG Fuse Mounting Angle 40X40X5mm	1 No
4.	Tinned Coated Copper Fuse Wire ϕ 2mm of Length 203mm (Only for Testing Purpose)	-
5.	Polymer Insulator	3 Nos
6.	Insulator Support Bird Fault Proof Clamp 30X5mm	6 Nos
7.	Connectors Suitable for fixing Brass Jumpers 30X1.8	3 Nos
8.	Connectors Suitable for ACSR Conductors	-
9.	No of Sheds	6
10.	Horizontal Support Angle 40X40X5mm	2 Nos
11.	Bent Support Angles 40X40X5mm	2 Nos
12.	Fuse Fixing Screws with Wing Nut & Flat Washer	6 Nos

Tolerance: \pm 5%

1. All Dimensions are in mm,
2. All Ferrous Parts Except Mounting Angles are Hot Dip Galvanized,
3. Mounting Angles are painted with double coat Red Oxide,
4. The Central Metallic Support where it grips the insulator is insulated to the insulation level of insulator to avoid Bird Faults,
5. All Bolts, Nuts & Flat Washers are Electro Plating.

Customer Name	Anjaneya Engineering Industries, Hyderabad
P.O No	CGM/P&MM/EPDCL/VSP/P3/EPMP-19/24-25/PO-5100005109/24.
Date	27.08.2024
Title	11KV HG Fuse Sets with Polymer Insulators

**GUARANTEED TECHNICAL PARTICULARS OF 11 KV HG FUSE SETS WITH
POLYMER INSULATORS:**

1. Manufacturer's Name :
2. Type :
3. Rated Current :
4. Rated Voltage :
5. Rated insulation level :
 - a) Power frequency withstanding voltage :
 - i) To earth and between poles :
 - ii) Across isolating distance :
 - b) Impulse withstand voltage :
 - i) To earth and between poles :
 - ii) Across isolating distance :
6. Temperature rise :
7. Resistance across the terminals (excluding fuse wire resistance) :
8. The gap for the fuse wire :
9. Phase to phase clearance of the fuse set :
10. Insulator support material and dimension :
11. Arcing horn straight portion :
12. Arcing horn bending portion (i.e. from 60 degree angle) :

INSULATORS:

1. Make : Any standard make.
2. Type : Polymer insulators
3. Power frequency withstand voltage dry/Wet.
4. Impulse withstand voltage :
5. Visible discharge voltage :
6. Creepage distance :
(Moderately polluted atmosphere)
7. Flash over voltage Dry/Wet.
8. Total length of the insulator :
9. Dia. of the insulator :

ANNEXURE – I

LIST OF MATERIALS FOR 11 KV HG FUSE SETS

Sl. No.	Particulars	Material	Size	Quantity
1	Polymer insulators	Polymer	As per drawing	3 Nos.
2	Arcing horns	MSHDG	8 mm Ø (each 560 mm length)	6 Nos.
3	Horn supports	MSHDG	30 x 3 mm	12 Nos.
4	Insulator Supports with bird fault proof arrangement (Polyaurothelene coated)	MSHDG	30 x 5 mm	6 Nos.
5	Brass bolts with wing type nuts and washers	Brass (Tin plated)	3"/16 x 1/2"	6 Nos.
6	Bolts & Nuts with Flat and spring washers	MSHDG	M8 (5"/16) x 25 mm	24 Nos.
7	- do -	MSHDG	M10 (3"/8) x 25 mm	10 Nos.
8	- do -	MSHDG	M12 (1"/2) x 225 mm	4 Nos.
9	Connectors:			
	a) Suitable for ACSR conductor (Mink)	Aluminium	---	3 Nos.
	b) Suitable for Brass Jumpers (Width : 30 mm, Thickness : 1.8 mm)	Aluminium	---	3 Nos.
10	Fuse set mounting Angle (to be painted with double coat of red oxide)	M.S. angles (Red oxide painted)	40 x 40 x 5 mm	1 Nos.
11	Horizontal support Angle	- do -	40 x 40 x 5 mm	2 Nos.
12	Bent support Angle	- do -	40 x 40 x 5 mm	2 Nos.

Note: 1) All the ferrous parts of the HG Fuse except mounting Angles shall be hot dip galvanized.

2) The mounting angles shall be painted with double coat of red oxide paint.

Sd/-

**CHIEF GENERAL MANAGER / P&MM
CORPORATE OFFICE :: A.P.C.P.D.C.L.
VIJAYAWADA
(Ph No. 0866-2955455)**